

## GROUND PLATES INSTALLATION INSTRUCTIONS



**RA206** -  $\varnothing$  55 mm (2 1/4") is conceived for tanks in order to neutralize static electricity on metal tanks or on metal parts inside of plastic tanks. *Supplied with 1 screw, 1 spacer and 2 nuts - Use: Tanks*



**RA202** -  $\varnothing$  128 mm (5"). Needs only one hole instead of the two needed to install rectangular plates. Ground equivalent Surface: 1.7 sq/mt. *Supplied with 1 screw, 1 spacer and 2 nuts - Use: Generators general grounding*



**RA203** - 155x51x13mm (6x2x1/2"). Ground equivalent Surface: 1,15 sq/mt *Supplied with 2 screws, 2 spacer and 3 nuts - Use: Generators general grounding*



**RA204** - 205x64x13mm (8x2 1/2x1/2"). Ground equivalent Surface: 2 sq/mt *Supplied with 2 screws, 2 spacer and 3 nuts - Use: 2 plates for SSB 400W*



**RA205** - 300x80x13mm (12x3x1/2"). Ground equivalent Surface: 3,45 sq/mt. *Supplied with 2 screws, 2 spacer and 3 nuts Use: 2 plates for SSB 800W*



**RA207** - 455x150x13mm (18x6x1/2"). Ground equivalent Surface: 5,75 sq/mt. *Supplied with 4 screws, 4 spacer and 5 nuts - Use: 2 plates for SSB 800W (or more)*



### Description

The ground plates are a necessary interface between on board electronic devices and the heat sink: water. Glomex ground plates are made of golden sintered bronze, that is, they consist of a million microspheres creating a surface more than 10 times bigger than the actual size. They can have either a rectangular or a circular shape, and are fastened to the hull by means of **bronze bolts (the same material of Glomex ground plates)** and nuts, highly resistant to corrosion, and rubber spacers. The exclusive shape offered by Glomex assures a larger surface and a better strength – **about 15% more of standard plates**

### How mounting the Glomex ground plates

#### First of all choose the mounting location

Choose a mounting location that will always be submerged.

-  On a powerboat, the best location is usually any flat area on the aft third of the bottom of the hull close to the vessel's centreline. Please avoid mounting the ground plates on the vessel's transom.
-  On a sailboat, the best location is a flat location on the aft half of the hull and close to the centreline.

Be careful to avoid mounting the ground plates immediately forward of any depth finder or knot meter or any other transducers. The turbulence directly aft of the ground plates may affect the performance of some devices. On choosing the best mounting location, please consider the thickness of the hull and be sure you will have access to the inside of the hull in that area to tighten fasteners and make wiring connections. Be careful to avoid areas where drilling may damage fuel or water tanks, plumbing, or wiring, etc.

#### Then, preparing the selected mounting location

After you have selected the mounting location for your ground plate:

- a) Use the ground plates as a template for marking the locations of its mounting holes onto the hull. Check the technical drawing above of your ground plates to determine which size drill bit you will need, then drill the holes at the marked locations.
- b) Hold the ground plates against the outside of the hull where you have planned to mount it. Align the ground plate parallel with the centreline of your vessel, with its sloped ends pointing fore and aft.
- c) Observe the gap between the ground plate and hull. If any edge of the ground plate is more than 3 mm (1/8") from the surface of the hull, please select a flatter mounting location.
- d) If the mounting location is suitable, use a pencil to mark the centres of the holes in the ground plates onto the hull.
- e) Drill one hole at one marked location on the hull. Before drilling any other holes, please examine the inside of the hull to confirm that the mounting location is suitable. If so, drill the other hole(s) through the hull at the marked location(s).
- f) The ground plates must be attached to the hull, otherwise the fixing bolt can be corroded by the water turbulences. Glomex doesn't accept any responsibility for an incorrect installation.

Mounting the ground plate (see fig. A)

Fig. A

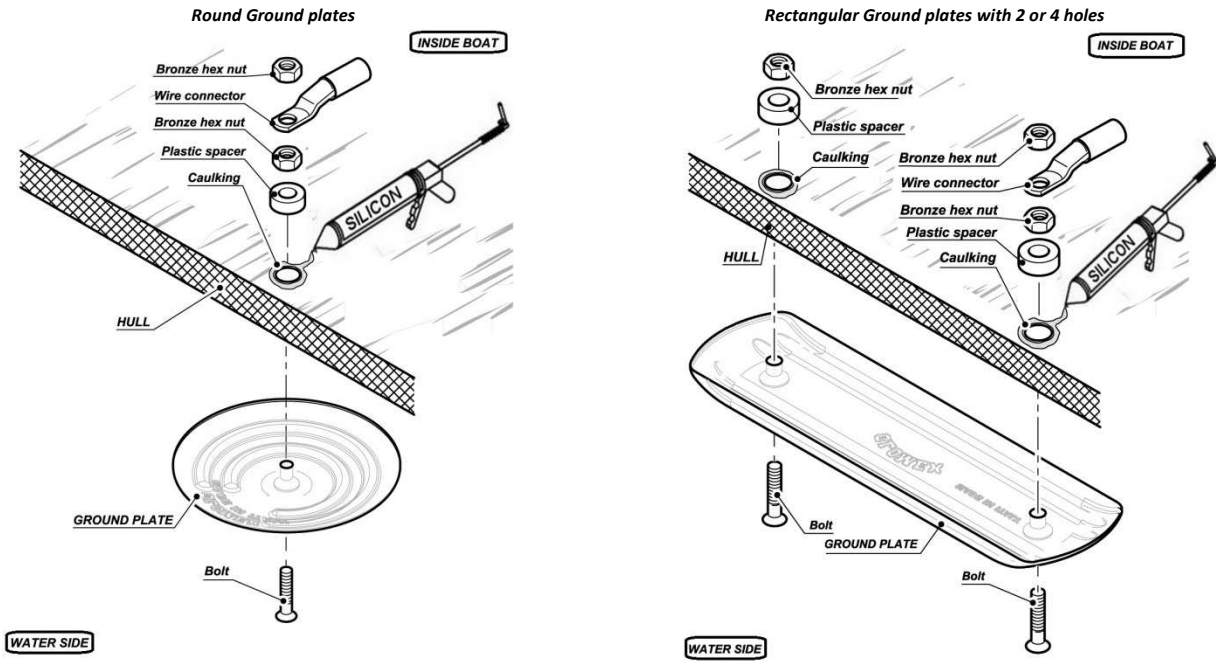

1. Clean and dry the inside surface of the hull around the mounting location. It is very important to remove any grease or oil that could prevent the caulking to adhere to the hull.
2. Apply a bead of underwater caulking sealant to the inside of the hull in a circle around each mounting hole. Squeeze a small amount of caulking into each mounting hole. (Be careful: **do not** coat the back of the ground plate with sealant.)
3. Align the ground plate over the mounting holes on the outside of the hull. Mount the ground plate by passing the bronze bolt(s) through the ground plate and hull. Fasten with flat washer(s) and nut as shown in Fig. A. Tighten the nut(s) hand-tight.
4. Use a wrench to tighten the nuts inside the hull while someone else uses a large slot head screwdriver to hold the bolts from outside the hull. Do not over tighten.
5. Make the electrical connections to the bolt. Use #8 gauge minimum size stranded copper wire with a ring terminal to connect the ground plate to your system ground and/or your DC accessories' negative ground. Use a wire equal in size to the negative battery cable to connect the negative post of your battery to the ground plate.
6. If you need to connect the plate to a copper band use a 50 mm (2") (minimum size) copper band, and avoid any possible curve or bending of the copper plate. The best performances are obtained going straight to the radio antenna coupler.

### Maintenance

Do not paint the Ground plate.

It is difficult for barnacles to attach themselves onto its porous surface.

Clean with stiff brush and bleach. Inspect annually. Change the plate if corroded or so dirty that you cannot clean it adequately.

### Technical drawings

